



### Standard Features

- Stake Pockets and Rub Rails
- HD Front/Rear Side Steps
- 8K Slipper Spring Axles
- 3-Way Gate
- Scissor Hoist – Power Up / Power Down
- Adjustable Coupler
- Aluminum Toolbox
- 110V Battery Charger
- 10W Solar Panel
- PPG DTM 2 Part Epoxy Paint
- Fully Enclosed Wiring
- HSS Structural Tubing
- Engineered Sill Design
- Spare Tire\*
- Aluminum Slide in Ramps\*
- Roll Up Tarp\*
- Rear Drop Down Stabilizer Jacks\*
- Side Boards\*

\*Dealer Specific Options

### Specifications

<b>Axle:</b>	(2) 8,000 lb Lippert Spring	<b>Floor &amp; Wall:</b>	10GA Floor / 10GA Wall
<b>Hoist:</b>	Champion CS615T 9 Ton	<b>Frame:</b>	6" X 2" X 0.188" HSS
<b>Jack:</b>	12,000 lb Side Wind Jack Bolted	<b>Lights:</b>	LED
<b>Ramp:</b>	4,500 lb Mid Span Aluminum	<b>Electric Plug:</b>	7 Wire RV
<b>Wheels:</b>	235/85R16 F Steel	<b>Safety Chains:</b>	16,200 lb
<b>Tailgate:</b>	Steel Three Way Barn/Spreader	<b>Paint Specs:</b>	PPG 2-Part Epoxy DTM
<b>Coupler:</b>	21,000 lb Demco Adjustable	<b>Dump Angle:</b>	45°

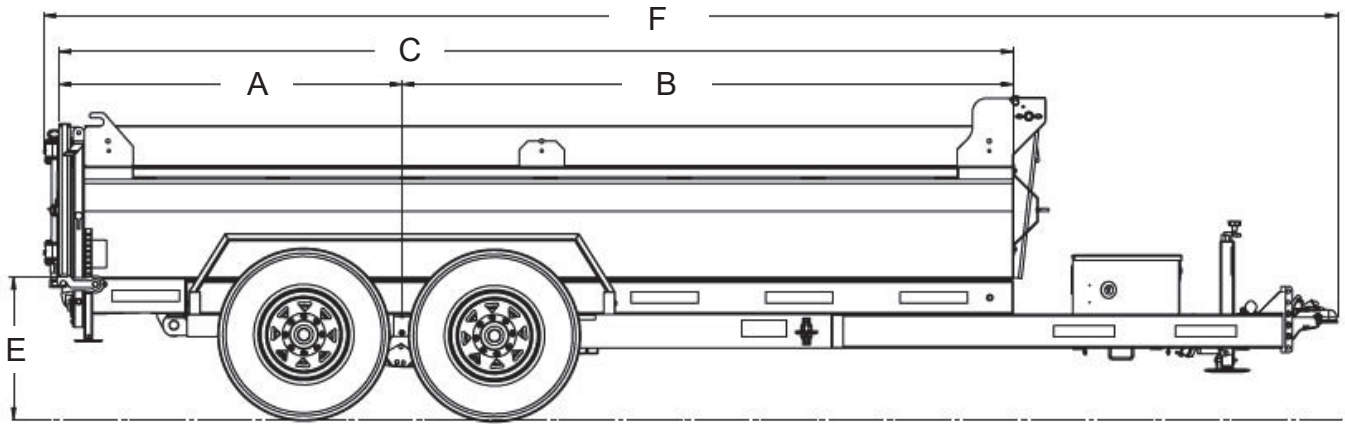

## Dimensions

Model	A	B	C	D	E	F	Box Width
SL714-16K	60 1/2"	112 3/4"	173 1/4"	179"	25"	232 3/4"	82 1/2"

Model	Description	Net Weight	GVWR	Payload Cap.
SL714-16K	7' x 14' 16,000 lb. Tandem Axle Black/Charcoal	4,180 lb	17,421 lb	13,241 lb



Specs are subject to change without notice. Please contact Southland Trailers Product Specialist for price confirmation on all Products. - Revised January 2025