



Standard Features

- Fully Enclosed Wiring w/LED Lights
- Bolted Fenders
- Available in straight deck or beavertail
- Available with slide in or fold up ramps
- Stabilizer jacks standard on slide-in ramps
- High tensile steel I-beam crossmembers
- HSS Structural Tubing Frame
- HD Fir Decking
- Bolted Drop Leg Jacks
- Stake pockets and rub rail

Specifications

Axle:	(2) 5,200 lb Lippert Spring	Frame:	6 X 2 HSS
Suspension:	Multi-Leaf Spring w/Equalizer	Ramp:	Slide In or Flip Up, 4,000 lb
Wheels:	225/75R15 D Steel	Crossmember:	3" I-Beam 80 KSI
Brakes:	Electric Self Adjusting	Tongue:	6 X 2 HSS
Jack:	5,000 lb Top Wind Bolted	Deck:	HD Fir Plank
Coupler:	21,000 lb Demco Adjustable	Electric Plug:	7 Wire RV

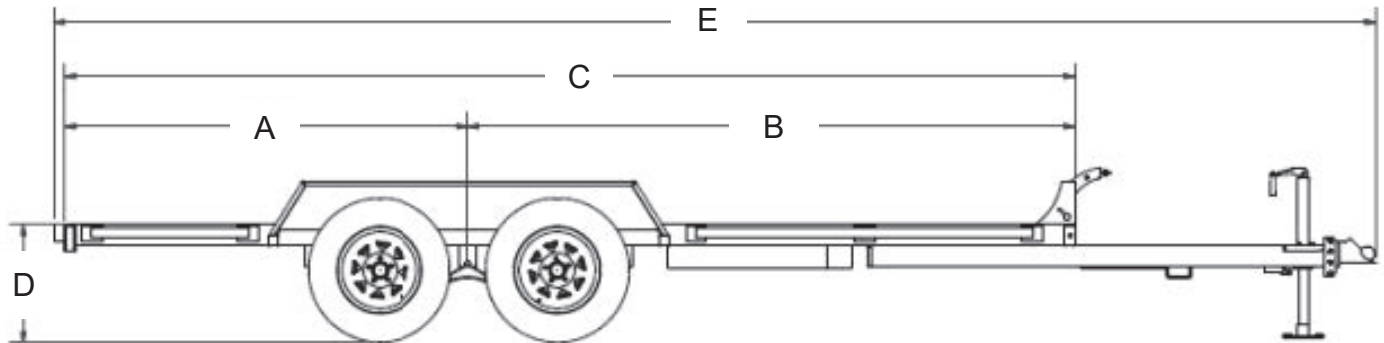

Dimensions

Model	A	B	C	D	E
LBAT52-16	78"	114"	192"	23"	248"
LBAT52-18	86"	130"	216"	23"	272"
LBAT52-20	96"	144"	240"	23"	296"
LBAT52-22	112"	152"	264"	23"	320"

Width Between Fenders

81"

Model	Description	Net Weight	GVWR	Payload Cap.
LBAT52-16	16' 5,200 lb. Tandem Axle Black	2,000 lb.	11,440 lb.	9,440 lb.
LBAT52-18	18' 5,200 lb. Tandem Axle Black	2,150 lb.	11,440 lb.	9,290 lb.
LBAT52-20	20' 5,200 lb. Tandem Axle Black	2,300 lb.	11,440 lb.	9,140 lb.
LBAT52-22	22' 5,200 lb. Tandem Axle Black	2,450 lb.	11,440 lb.	8,990 lb.



Specs are subject to change without notice. Please contact Southland Trailer Corp Product Specialist for price confirmation on all Products. - Revised July 2024